

1 2 3 4 5 6 7 8

REVISIONS		
ISS	ZONE	DESCRIPTION\PER REQUEST\DATE
B	A-1	NO.1 WAS CHANGED\RD-DM88031601B\03-16-99'
		NO.5 WAS CHANGED\RD-DM88041901B\04-19-99'
C	A-1	NO.6 WAS CHANGED\RD-DM88112901B\11-29-99'

業務部

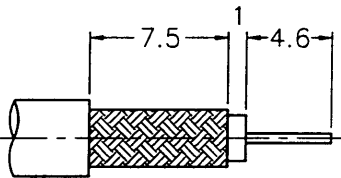

RECOMMENDED
CABLE STRIPPING DIM'S
(建議剝線尺寸)

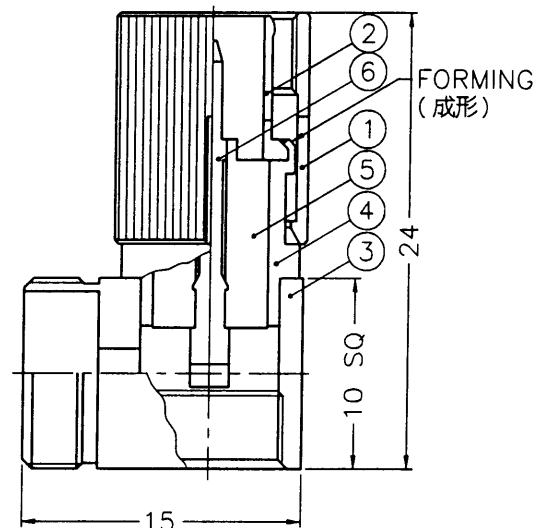
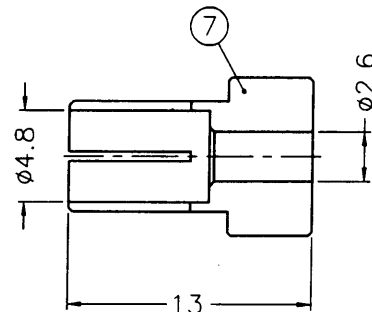
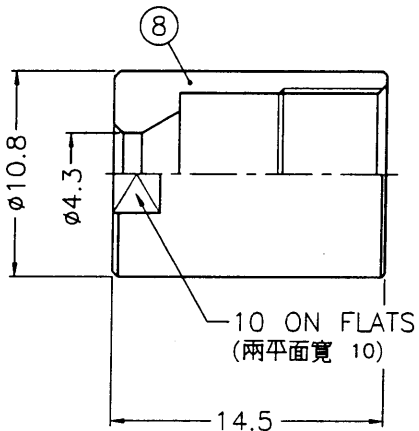

- NOTES: FINISH (PLATING THICKNESS IN MICRO-INCHES)
- BRASS PER QQ-B-626
 - NICKEL PL. 100 MIN. THICK OVER COPPER STRIKE
 - PHOSPHOR BRONZE PER QQ-B-750
 - GOLD PL. 3 MIN. THICK OVER NICKEL PL. 100 MIN. THICK OVER COPPER STRIKE
 - TEFLON MIL-P-19468

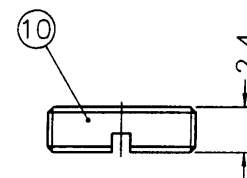
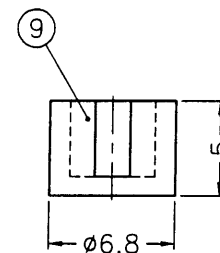

出圖
89.7.11
設計部

10	NUT	NOTE 1	NOTE 2	1	15687061606-5
9	INSULATOR	DELTRIN	NATURAL	1	15687061606-4
8	NUT	NOTE 1	NOTE 2	1	1566442A1-7-43
7	BRAID CLAMP	NOTE 1	NOTE 2	1	1566442A1-6-48 /26
6	CONTACT PIN	NOTE 1	NOTE 4	1	1561112A1-6-B
5	INSULATOR	NOTE 5	NATURAL	1	1561112A1-5-B
4	BODY	NOTE 1	NOTE 2	1	1561112A1-4
3	HOUSING	NOTE 1	NOTE 2	1	1566442A1-2-26
2	OUT CONTACT	NOTE 3	NOTE 4	1	1561121G1-2
1	SHELL	NOTE 1	NOTE 2	1	1561121G1-1-B
NO.	DESCRIPTION	MATERIAL	FINISH	Q'TY	DRAWING NO.

DIMENSIONS ARE IN MILLIMETERS
UNLESS OTHERWISE SPECIFIED TOLERANCES

0.5-6 = ±0.2
6-30 = ±0.4
30-120 = ±0.6
120-315 = ±1
315-1000 = ±1.6
1000-2000 = ±2.4

PART NO.	
APPROVED	DATE 07-10-00'
CHECKED	DATE 07-10-00'
DRAWN	DATE 07-10-00'

Amphenol - Kai Jack	
TAINAN TAIWAN	
TITLE	1.6-5.6 R/A CLAMP PLUG
DRAWING NO.	KJ-1561142A1-N/3GT3G-2.5C2V-75
FILE NO.	F:\DWG\156\1142A1\25C2V-75\N-3GT3G

F
E
D
C
B
A

F
E
I
C
E
A

1 2 3 4 5 6 7 8

82DOR